

1 . Introduction

E30-TTL-100

1.1 Feature

E30-TTL-100



E30-TTL-100 is a 100mW wireless transceiver module with narrow-band transmission, operates at 425-450.5MHz (default: 433MHz), based on original imported RFIC SI4463/SI4438 from Silicon Labs, transparent transmission is available, WOR (ultra-low power consumption), TTL level.

The module features FEC (Forward Error Correction) algorithm, which ensure its high coding efficiency & good correction performance. In the case of sudden interference, it can correct the interfered data packets automatically, so that the reliability & transmission range are improved correspondingly. But without FEC, those date packets can only be dropped.

The module has the function of data encryption & compression. The data of the module transmit in the air features randomness. And with the rigorous encryption & decryption, data interception becomes pointless. The function of data compression can decrease the transmission time & probability of being interference, while improving the reliability & transmission efficiency.

1.2 Basic usage

E30-TTL-100

No.	Usage	Description
1	Transparent transmission	Default Module A transmits 01 02 03 to module B, then module B receives 01 02 03.
2	Fixed transmission	Module can communicate with other modules in different channels, easy for networking and repeater. Module A transmits AA BB CC to module B (address: 0x00 01, channel: 0x80), HEX format is 00 01 80 AA BB CC (00 01 refers to the address of module B, 80 refers to the channel of module B), then module B receives AA BB CC (only module B).
3	Broadcast transmission	Set the module address as 0xFFFF, then the module can communicate with other modules in same channel.
4	Power-saving	In power-saving mode, the module' s maximum receiving response time is 2000ms, which the average current is below 50uA.
5	Sleep	When the module works in sleep mode, transmitting & receiving is not available, while the configuration is available. The typical current is 2.0uA in this mode.
See more details in related manual about fixed transmission and broadcast transmission.		

1.3 Electrical parameter

E30-TTL-100

No.	Parameter item	Parameter details & Description
1	Size	21 * 36mm, Without antenna and SMA
2	Frequency Band	425 – 450.5MHz Default: 433.0MHz, channel:256, 100kHz stepped frequency , Recommending frequency: 433±5MHz
3	Connector	1 * 7 * 2.54mm Plug-in
4	Supply voltage	2.1 - 5.5V DC Note: the voltage higher than 5.5V is forbidden
5	Communication level	UART, USART
6	Operation Range	About 2000m Test condition : clear and open area& maximum power , antenna gain: 5dBi , height:> 2m , air date rate: 1kbps
7	Transmitting power	Maximum 20dBm (100mW) Four optional level (0-3) , step by 3dB
8	Air data rate	Default 1kbps Can be configured to 1、 2、 5、 8、 10、 15、 20、 25kbps
9	Standby current	2.0uA M1=1,M0=1 (Mode 3)
10	Transmitting current	89mA@20dBm
11	Receiving current	16mA (Mode 0 or Mode 1) Minimum 30uA (Mode 2 + 2s wake-up time)
12	Communication interface	UART , 8N1、 8E1、 8O1 , Eight kinds of UART baud Rate, from 1200 to 115200 bps
13	Driving mode	UART can be configured to push-pull/high pull, open-drain
14	Transmitting length	512 bytes buffer , 58 bytes per package
15	Receiving length	512 bytes buffer , 58 bytes per package
16	Address	65536 configurable addresses Easy for network, broadcast and fixed transmission
17	RSSI support	Built-in intelligent processing
18	Sensitivity	-121dBm@1kbps Sensitivity has nothing to do with serial baud rate and timing
19	Antenna type	SMA-K External thread hole, 50 ohm impedance
20	Operating temperature	-40 ~ +85°C
21	Operating temperature	10% ~ 90%
22	Storage temperature	-40 ~ +125°C

2 . Functional description

E30-TTL-100

2.1 Pin definition

E30-TTL-100

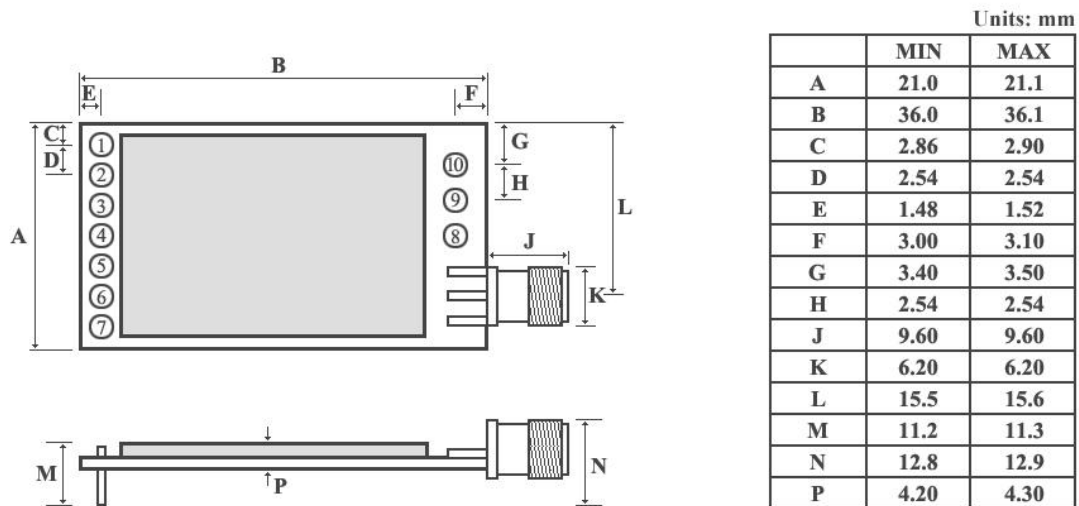

Pin No.	Pin item	Pin direction	Pin application
1	M0	Input (weak pull-up)	Work with M1 & decide the four operating modes. Floating is not allowed, can be ground.
2	M1	Input (weak pull-up)	Work with M0 & decide the four operating modes. Floating is not allowed, can be ground.
3	RXD	Input	TTL UART inputs, connects to external (MCU, PC) TXD output pin. Can be configured as open-drain or pull-up input.
4	TXD	Output	TTL UART outputs, connects to external RXD (MCU, PC) input pin. Can be configured as open-drain or push-pull output
5	AUX	Output	To indicate module' s working status & wakes up the external MCU. During the procedure of self-check initialization, the pin outputs low level. Can be configured as open-drain output or push-pull output (floating is allowed).
6	VCC		Power supply 2.1V-5.5V DC
7	GND		Ground
8	Fixing hole		Fixing hole
9	Fixing hole		Fixing hole
10	Fixing hole		Fixing hole
★★★ E30-TTL-100 can be compatible with other E30 series. ★★★			

2.2 Connect to MCU **E30-TTL-100**

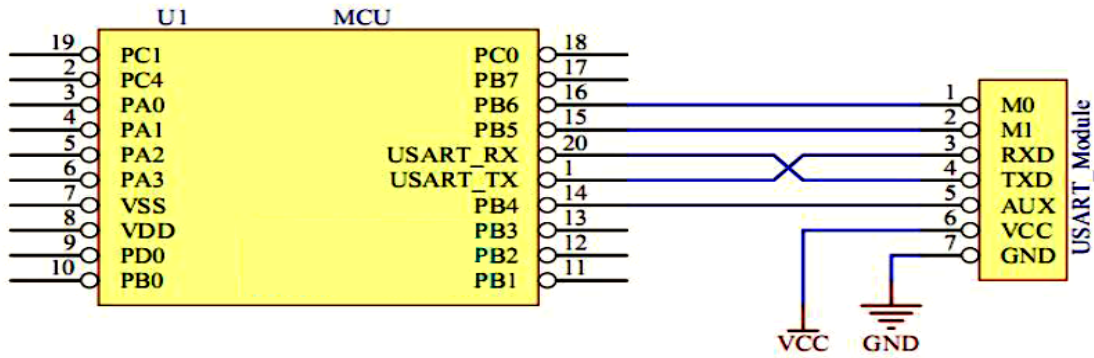

No.	Description (STM8L MCU)
1	The UART module is TTL level.
2	For some MCU works at 5VDC, it may need to add 4-10K pull-up resistor for the TXD & AUX pin.

2.3 Reset **E30-TTL-100**

No.	Description
1	When the module is powered, AUX outputs low level immediately, conducts hardware self-check and set the operating mode on the basis of the user parameters. During the process, the AUX keeps low level. After the process completes, the AUX outputs high level and starts to work as per the operating mode combined by M1 and A0. Therefore, the user needs to wait the AUX rising edge as the starting point of module' s normal work.

2.4 AUX description **E30-TTL-100**

AUX Pin can be used as indication for wireless send & receive buffer and self-check. It can indicate whether there are data that are yet to send through wireless, or whether all wireless data has sent through UART, or whether the module is still in the process of self-check initialization.

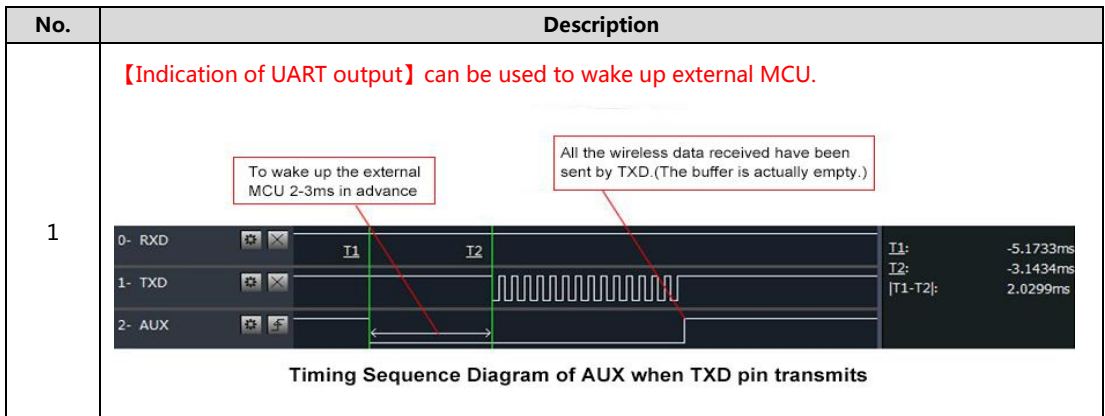

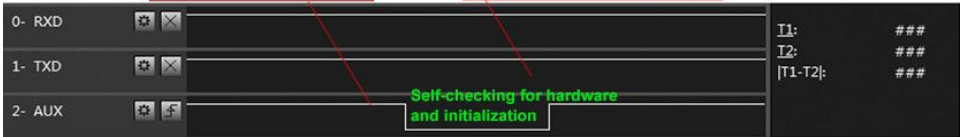
<p>2</p>	<p>【Indication of wireless transmitting】</p> <p>Buffer (empty): the internal 512 bytes data in the buffer are written to the RFIC (Auto subpackage). When AUX=1, the user can input data less than 512 bytes continuously without overflow.</p> <p>Buffer (not empty): when AUX=0, the internal 512 bytes data in the buffer have not written to the RFIC completely. If the user starts to transmit data at this circumstance, it may cause overtime when the module is waiting for the user date, or transmitting wireless subpackage.</p> <p>Notes: When AUX = 1, it does not mean that all the UART data of the module have been transmitted already, perhaps the last packet of data is still in transmission.</p> <div style="border: 1px solid black; padding: 5px; margin: 10px auto; width: fit-content;"> <p>Subpackage transmitting : the last package of data have been written to the RFIC. When transmission is on, user can continue to input 512 new bytes. (The buffer is actually empty.)</p> </div>  <p style="text-align: center;">Timing Sequence Diagram of AUX when RXD pin receives</p>
<p>3</p>	<p>【Configuration procedure of module】</p> <p>Only happened in the process of power-on and exit sleep mode.</p> <div style="border: 1px solid black; padding: 5px; margin: 10px auto; width: fit-content;"> <p>The self-check procedure happens when the procedure of power-on reset, instruction reset and exit mode 3.</p> </div> <div style="border: 1px solid black; padding: 5px; margin: 10px auto; width: fit-content;"> <p>Normal operation after self-check</p> </div>  <p style="text-align: center;">Timing Sequence Diagram of AUX when self-check</p>

No.	Notes for AUX
1	For function 1 & function 2 mentioned above, the priority should be given to the one with low level output, which means if it meets each of any low level output condition, AUX outputs low level, if none of the low level condition is meet, AUX outputs high level.
2	When AUX outputs low level, it means the module is busy & cannot conduct operating mode checking. After AUX outputs high level 1ms later, it will complete the mode-switch task.
3	After switching to new operating mode, it won' t be work in the new mode immediately until AUX rising edge 2ms later. If AUX is on the high level, the operating mode switch can be effect immediately.
4	When the user switches to other operating modes from mode 3 (sleep mode) or it' s still in reset process, the module will reset user parameters, during which AUX outputs low level.

3 . Operating mode

E30-TTL-100

Contents in below table are the introduction of input status of M1 & M0 and their corresponding mode:

Mode (0-3)	M1	M0	Mode introduction	Remark
Mode 0 Normal	0	0	UART and wireless channel is open, transparent transmission is on.	The receiver must works in mode 0 or mode 1
Mode 1 Wake-up	0	1	UART and wireless channel is opened. The difference between normal mode and wake-up mode is it will add preamble code automatically before data packet transmission so that it can awaken the receiver works in mode 2.	The receiver can works in mode 0, mode 1 or mode 2.
Mode 2 Power-savin g	1	0	UART is disabled. Wireless module works at WOR mode (wake on radio). It will open the UART and transmit data after receive the wireless data.	1,the transmitter must works in mode 1 2,transmitting is not allowed in this mode
Mode 3 Sleep	1	1	Parameter setting.	

3.1 Mode switch

E30-TTL-100

No.	Remarks
1	The user can decide the operating mode by the combination of M1 and M0. The two GPIO of MCU can be used to control the mode-switch. After modifying M1 or M0, it will start to work in new mode 1 ms later if the module is free. If there are any serial data that is yet to finish wireless transmitting, it will start to work in new mode after the UART transmitting finishing. After the module receives the wireless data & transmits the data through serial port, it will start to work in new mode after the transmitting finishing. Therefore, the mode-switch is only workable when AUX outputs 1, otherwise it will delay.
2	For example, in mode 0 or mode 1, if the user inputs massive data consecutively and switches operating mode at the same time, the mode-switch operation is invalid. New mode checking can only be started after all the user' s data process completing. It is recommended that after check AUX pinout status and wait 2ms after AUX outputs high level, then switch the mode.
3	If the module switches from other modes to stand-by mode, it will be work in stand-by mode only after all the remained data process completing. The feature can be used to save power consumption. For example, the transmitter works in mode 0, after the external MCU transmits data "12345". It can switch to sleep mode immediately but not wait the rising edge of the AUX pin, also the user' s main MCU will go dormancy immediately. Then the module will transmit all the data through wireless transmission & go dormancy 1ms later automatically. Which reduce MCU working time & save power.
4	Likewise, this feature can be used in any mode-switch. The module will start to work in new mode within 1ms after completing present mode task, which enable the user to omit the procedure of AUX inquiry and switch mode swiftly. For example, when switch from transmitting mode to receiving mode, the user MCU can go dormancy in advance of mode-switch, using external interrupt function to get AUX change so that the mode-switch can be done.
5	This operation is very flexible and efficient. It is totally designed on the basis of the user MCU' s convenience, at the same time reduce the whole system work load as much as possible, increase the efficiency of system work and reduce power consumption.

3.2 Normal mode (Mode 0)**E30-TTL-100**

When M1 = 0 & M0 = 0, module works in mode 0	
Transmitting	<p>The module can receive the user data from serial port, and transmit wireless data package which length is 58 bytes. When the data inputted by user is up to 58 byte, the module will start wireless transmission. During which the user can input data continuously for transmission.</p> <p>When the required transmission bytes is less than 58 byte, the module will wait 3-byte time and treat it as data termination unless continuous data inputted by user. Then the module will transmit all the data through wireless channel.</p> <p>When the module receives the first data packet from user, the AUX outputs low level. After the module transmit all the data into RF chip & start transmission, AUX outputs high level.</p> <p>At this time, it means that the last wireless data package transmission has started, which enable the user to input another 512 bytes continuously. The data package transmitted from the module works in mode 0 can only be received by the module works in mode 0 or 1.</p>
Receiving	<p>The module keeps the wireless receive function on, it can receive the data packet transmitted from the module works in mode 0 & mode 1. After receiving the data packet, the AUX outputs low level, 5ms later the module starts to transmit wireless data through serial port TXD pin. After all the wireless data have been transmitted via serial port, the module AUX outputs high level.</p>

3.3 Wake-up mode (Mode 1)**E30-TTL-100**

When M1 = 0 & M0 = 1, module works in mode 1.	
Transmitting	<p>The condition of data packet transmission & AUX function is the same as mode 0. The only difference is that the module will add preamble code before each data packet automatically. The preamble code length depends on the wake-up time set in the user parameters. The purpose of the preamble code is waking up the receiving module works in mode 2. Therefore, the data package transmitted from mode 1 can be received by mode 0, mode1 and mode 2.</p>
Receiving	<p>The same as that in mode 0.</p>

3.4 Power-saving mode (Mode 2)**E30-TTL-100**

When M1 = 1 & M0 = 0, module works in mode 2.	
Transmitting	<p>UART is closed, the module cannot receive any serial port data from outside MCU. Hence the module works in this mode does not have the function of wireless transmission.</p>
Receiving	<p>In mode 2, it is required the date transmitter works in mode 1.</p> <p>The wireless module monitors the preamble code at regular time. Once it gets the preamble code, it will remain as receive status and wait for the completion of the entire valid date package receives. Then the module lets the AUX outputs low level, 5ms later opens the serial port to transmit received wireless data through TXD. Finally AUX outputs high level after process completing.</p>

	The wireless module stays in “power-saving – monitoring” working status (polling). By setting different wake-up time, the module can have different receive response delay (2s maximum) and average power consumption (30uA minimum). The user needs to achieve a balance between communication delay time & average power consumption.
--	---

3.5 Sleep mode (Mode 3) E30-TTL-100

When M1=1,M0=1,module works in mode 3	
Transmitting	N/A
Receiving	N/A
Parameter setting	This mode can be used for parameter setting. It uses serial port 9600 & 8N1 to set module working parameters through specific instruction format. (pls refer to parameters setting for details)
Notes	When the mode changes from stand-by mode to others, the module will reset its parameters, during which the AUX keeps low level and then outputs high level after reset completing. It is recommended to check the AUX rising edge for user.

3.6 Quick communication test E30-TTL-100

Steps	Operation
1	Plug the USB test board (E15-USB-T2) into computer, make sure the driver is installed correctly. Plug mode-select jumper in the USB test board (M1 = 0 , M0 = 0), make the module work in mode 0.
2	Optional power supply, 3.3V or 5V.
3	Operate AccessPort software and select the correct serial port code. See figure 7.

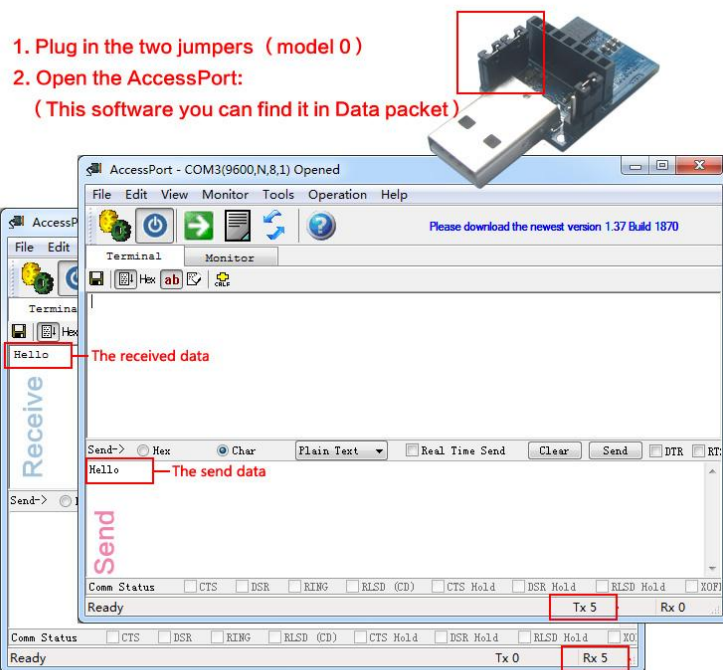

4 . Instruction format

E30-TTL-100

In sleep mode (mode 3 : M1=1, M0=1) , it supports below instructions on list.

(Only support 9600 and 8N1 format when setting)

No.	Instruction format	Illustration
1	C0 + working parameters	C0 + 5 bytes working parameters are sent in hexadecimal format. 6 bytes in total and must send in succession. (Save the parameters when power-down)
2	C1 C1 C1	Three C1 are sent in hexadecimal format. The module returns the saved parameters and must send in succession.
3	C2 + working parameters	C2 + 5 bytes working parameters are sent in hexadecimal format. 6 bytes in total and must send in succession. (Not save the parameters when power-down)
4	C3 C3 C3	Three C3 are sent in hexadecimal format. The module returns the version information and must send in succession.
5	C4 C4 C4	Three C4 are sent in hexadecimal format. The module will reset one time and must send in succession.

4.1 Default parameter

E30-TTL-100

Default parameter values : C0 00 00 18 50 40							
Model	Frequency	Address	Channel	Air data rate	Baud rate	Parity	Transmitting power
E30-TTL-100	433MHz	0x0000	0x50	1kbps	9600	8N1	100mW

4.2 Parameter setting instruction

E30-TTL-100

The difference between C0 command and C2 command is that C0 command will write parameters into the internal flash memory and can be saved when power down, while C2 command cannot be saved when power down, because C2 command is temporarily mend instruction.

C2 is recommended for the occasion that need to change the operating parameters frequently,
Like C2 00 00 18 50 40.

No.	Item	Description	Remark
0	HEAD	Fix 0xC0 or 0xC2, it means this frame data is control command	Must be 0xC0 or 0xC2 C0: Save the parameters when power-down C2: Not save the parameters when power-down
1	ADDH	High address byte of module (the default 00H)	00H-FFH
2	ADDL	Low address byte of module	00H-FFH

		(the default 00H)	
3	SPED	<p>Rate parameter , including UART baud rate and air date rate</p> <p>7 , 6 UART parity bit 00 : 8N1 (default) 01 : 8O1 10 : 8E1 11 : 8N1 (equal to 00)</p> <p>-----</p> <p>5 , 4 , 3 TTL UART baud rate (bps) 000 : 1200bps 001 : 2400bps 010 : 4800bps 011 : 9600bps (default) 100 : 19200bps 101 : 38400bps 110 : 57600bps 111 : 115200bps</p> <p>-----</p> <p>2 , 1 , 0 Air date rate (bps) 000 : 1Kbps (default) 001 : 2Kbps 010 : 5Kbps 011 : 8Kbps 100 : 10Kbps 101 : 15Kbps 110 : 20Kbps 111 : 25Kbps</p>	<ul style="list-style-type: none"> • UART mode can be different between communication parties <p>-----</p> <ul style="list-style-type: none"> • UART baud rate can be different between communication parties • The UART baud rate has nothing to do with wireless transmission parameters & won' t affect the wireless transmit / receive features. <p>-----</p> <ul style="list-style-type: none"> • The lower the air date rate, the longer the transmitting distance, better anti-interference performance and longer transmitting time • The air date rate must keep the same for both communication parties.
4	CHAN	<p>Communication frequency (425M + CHAN * 0.1M) default 50H (433MHz)</p>	<ul style="list-style-type: none"> • 00H- FFH , for 425 - 450.5Mhz
5	OPTION	<p>7 , Fixed transmission (similar to MODBUS) 0 : Transparent transmission mode (default) 1 : Fixed transmission mode</p> <p>-----</p> <p>6 IO drive mode(the default 1) 1 : TXD and AUX push-pull outputs, RXD pull-up inputs 0 : TXD、 AUX open-collector</p>	<ul style="list-style-type: none"> • In fixed transmission mode, the first three bytes of each user's data frame can be used as high/low address and channel. The module changes its address and channel when transmit. And it will revert to original setting after complete the process. <p>-----</p> <p>This bit is used to the module internal pull-up resistor. It also increases the level' s adaptability in case of open drain. But in some cases, it may need external pull-up resistor.</p>

		<p>outputs, RXD open-collector inputs</p> <p>-----</p> <p>5, 4, 3 wireless wake-up time (for the receiver, it means the monitor interval time ,while for the transmitter it means continuously sending preamble code time.)</p> <p>000 : 250ms (default) 001 : 500ms 010 : 750ms 011 : 1000ms 100 : 1250ms 101 : 1500ms 110 : 1750ms 111 : 2000ms</p> <p>-----</p> <p>2, FEC switch 0 : Turn off FEC 1 : Turn on FEC (Default)</p> <p>-----</p> <p>1, 0 transmission power (approximation) 00 : 20dBm (Default) 01 : 17dBm 10 : 14dBm 11 : 10dBm</p>	<p>-----</p> <ul style="list-style-type: none"> • The transmit & receive module work in mode 0, whose delay time is invalid & can be arbitrary value. • The transmitter works in mode 1 can transmit the preamble code of the corresponding time continuously. • When the receiver works in mode 2, the time means the monitor interval time (wireless wake-up). Only the data from transmitter that works in mode 1 can be received. • The wake-up time set by transmitter cannot be less than the monitor interval time of receiver; otherwise, it may lead to data loss. In case of two-way communication, both parties should keep the wake-up time the same. • The longer the wake-up time, the lower the average receive current consumption. <p>-----</p> <ul style="list-style-type: none"> • After turn off FEC, the actual data transmission rate increases while anti-interference ability decreases. Also the transmission distance is relatively short. Both communication parties must keep on the same pages about turn-on or turn-off FEC. <p>-----</p> <ul style="list-style-type: none"> • The external power must make sure the ability of current output more than 200mA and ensure the power supply ripple within 100mV. Low power transmission is not recommended due to its low power supply efficiency.
--	--	--	--

For example: The meaning of No.3 "SPED" byte :

The binary bit of the byte	7	6	5	4	3	2	1	0
The specific value (user configures)	0	0	0	1	1	0	0	0
Meaning	UART parity bit 8N1		UART baud rate is 9600			Air data rate is 1k		
Corresponding hexadecimal	1				8			

4.3 Reading operating parameters

E30-TTL-100

Instruction format	Description
C1+C1+C1	In sleep mode (M0=1 , M1=1) , User gives the module instruction (HEX format): C1 C1 C1, Module returns the present configuration parameters. For example, C0 00 00 18 50 40.

4.4 Reading version number

E30-TTL-100

Instruction format	Description
C3+C3+C3	In sleep mode (M0=1 , M1=1) , User gives the module instruction (HEX format): C3 C3 C3, Module returns its present version number, for example C3 30 xx yy. 30 here means the module model (E30 series); xx is the version number and yy refers to the other module features.

4.5 Reset instruction

E30-TTL-100

Instruction format	Description
C4+C4+C4	In sleep mode (M0=1 , M1=1) , User gives the module instruction (HEX format): C4 C4 C4, the module resets for one time. During the reset process, the module will conduct self-check, AUX outputs low level. After reset completing, the AUX outputs high level, then the module starts to work regularly which the working mode can be switched or be given another instruction.

5 . Parameter setting

E30-TTL-100

Step	Operation	Description
1	Install Driver	Please install the USB adapter driver (CP2102).
2	Pull out the jumper	Pull the M0、 M1 jumper out, see figure 9 3.3V or 5V are available for jumper.
3	Connect to module	Connect the module with USB adapter. Connect to the USB interface of PC.
4	Open serial port	Operate the parameter setting software, choose corresponding serial number and press the "Open CommPort" button. Please choose other serial numbers until open successfully.
5	Interface	Press "Press to Read" button , the interface will be as figure 9 If failed, please check if the module is in mode 3, or the driver has been installed or not.
6	Input parameter	Please adjust the parameter as your request according to the corresponding setting, then click "Write" button, write the new parameter to the module
7	Complete the operation.	Please operate the "Fifth step" if you need to reconfigure, if the configuration is completed, Please click "close UART" and then take off the module.
8	Commands Configuration	Parameter configuration is also available for MCU (in mode 3).

